

One Source

Raptor® XL400 Cone Crushers



Raptor® XL400

Portable, versatile, produces more saleable product...

Our Raptor® cone crushers offer excellent flexibility and portability for secondary or tertiary crushing applications. Built to deliver a lifetime of productivity, they're backed by the kind of responsive service and support you deserve from a team of industry professionals with 100+ years of combined crusher experience.

Outstanding Gradation Control and Cubical Product

The XL400 is an ideal solution as a secondary crusher following a Jaw. This machine produces more usable and saleable aggregate per ton processed than competitive models in its class. Versatile and highly portable, the XL400 can also accept primary-crushed ore with greater flexibility (up to 25 percent larger material) due to its 52-inch (1.3m) head diameter, large feed opening, high-pivot-point crushing action and wide crushing stroke. Outstanding gradation control and cubical product make the XL400 an excellent tertiary crusher for aggregate, asphalt or concrete products.

Superior Bronze Bearing Technology

Raptor Cones utilize custom engineered bronze sleeve bearings for all internal moving load bearing or load transmission components. Counter-shaft Bushings, Thrust Bearings, Head and Eccentric Bushings, and Socket Liners are designed for superior performance.

Structural Integrity

Raptor's critical load bearing components meet specifications that typically exceed what is commonly offered in a conventional cone crusher. Our major components are cast of high grade steel, and our eccentric material selection provides greater certainty of a reliable surface finish, even after many years of service.

Mobility...

Because of our unique emphasis on high throw and high-pivot point crushing, the Raptor XL400 offers

significantly more productivity, yet is still highly portable and compact.

Versatility...

The Raptor cone crusher offers more flexibility in the production of high quality aggregates, asphalt or concrete products. The Raptor cone has also earned a leading reputation in the mining industry, operating in some of the most demanding mineral processing applications worldwide.

Security...

Raptor cone crushers employ "Fail Safe" hydraulics to ensure protection from mechanical overload should an accumulator bladder fail. Raptors require only one accumulator to operate safely and reliably. Should the accumulator fail, an internal relief valve within the dual acting tramp release cylinders provides immediate, alternate protection from severe and costly structural damage to the crusher. Another standard safety feature is the counterclockwise rotating crushing action. This prevents the machine from self-tightening the setting when adjustment ring movement is excessive, or if the ring gear brake fails.

Automation...

Raptor cone crushers employ advanced overload sensing technology to detect crushing force overload. A simple alarm can be activated. If desired, our advanced automation system can take the necessary corrective action. The same advanced automation system can be used to optimize crusher performance with feed control, setting adjustment and monitoring of critical lubrication and hydraulic parameters.

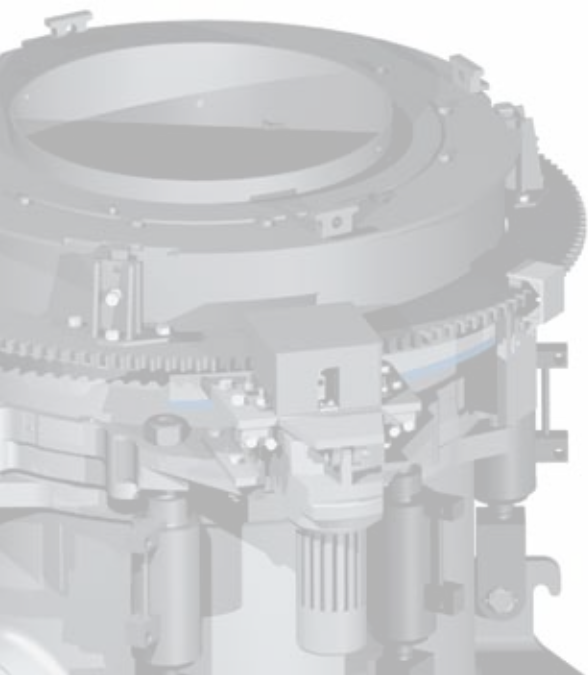

XL400 Clearance Dimensions

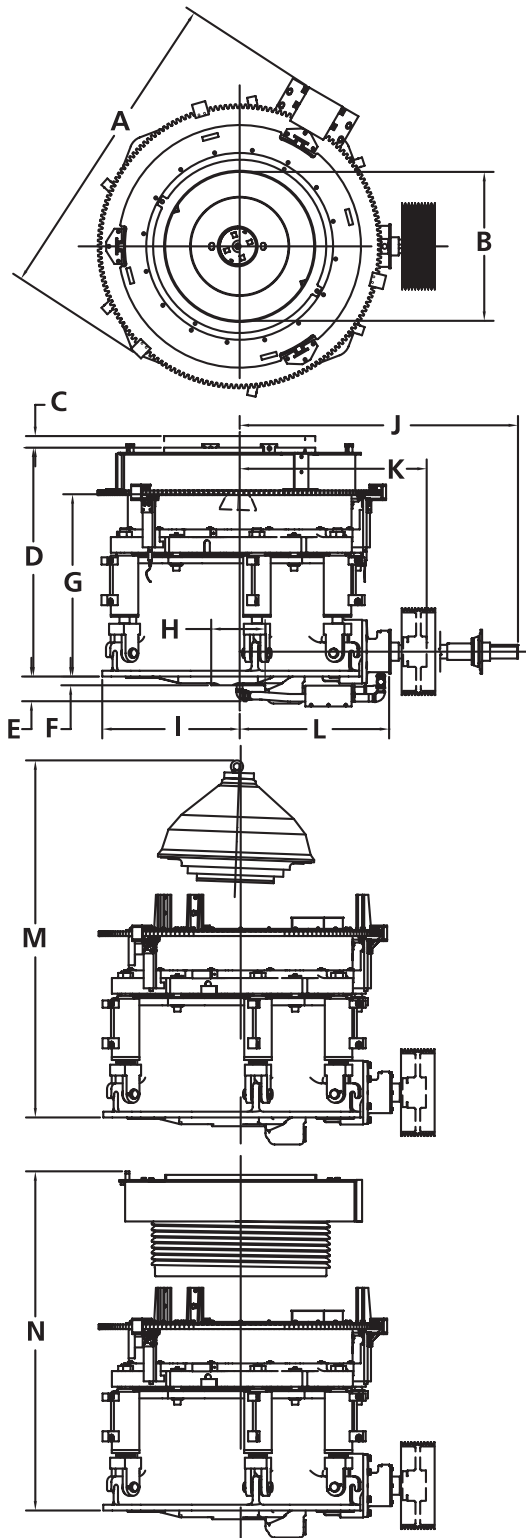

		(in)	(mm)
A	Adjustment Ring Max Diameter	112.43 in	2856 mm
B	Inside Diameter of Feed Hopper	51.50 in	1308 mm
C	Clearing Stroke Travel	5.16 in	131 mm
D	Height from Base to Top of Feed Hopper	79.11 in	2010 mm
E	Base to Bottom of Oil Piping	10.33 in	262 mm
F	Base to Bottom of Main Frame Hub	3.03 in	77 mm
G	Base to Top of Feed Plate Base to Top of Feed Plate (Anti-Spin)	63.02 in 65.93 in	1600 mm 1675 mm
H	Hub Diameter of Main Frame	19.69 in	500 mm
I	Crusher Centerline to Main Frame Flange	47.41 in	1207 mm
J	Clearance Required to Remove Countershaft Assemble	97.00 in	2464 mm
K	Crusher Centerline to End of Countershaft	64.58 in	1640 mm
L	Crusher Centerline to Countershaft Housing Face	42.32 in	1075 mm
M	Clearance Required to Remove Head Assembly Clearance Required to Remove Head Assembly (Anti-Spin)	124.00 in 127.00 in	3150 mm 3226 mm
N	Clearance Required to Remove Bowl Assembly	117.00 in	2972 mm

All dimensions are for reference only and are not to be used for construction.

Raptor® XL400 Cross Section

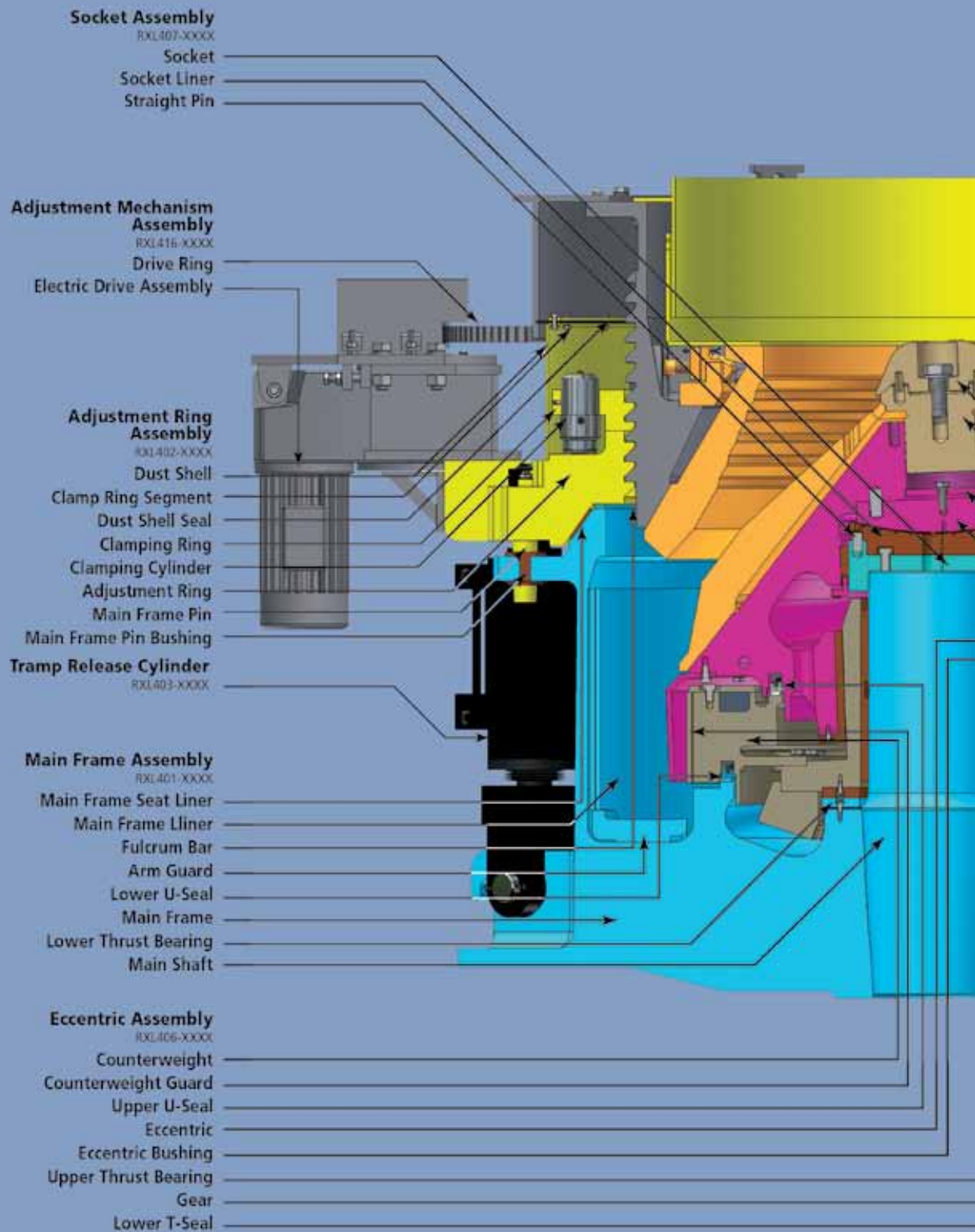

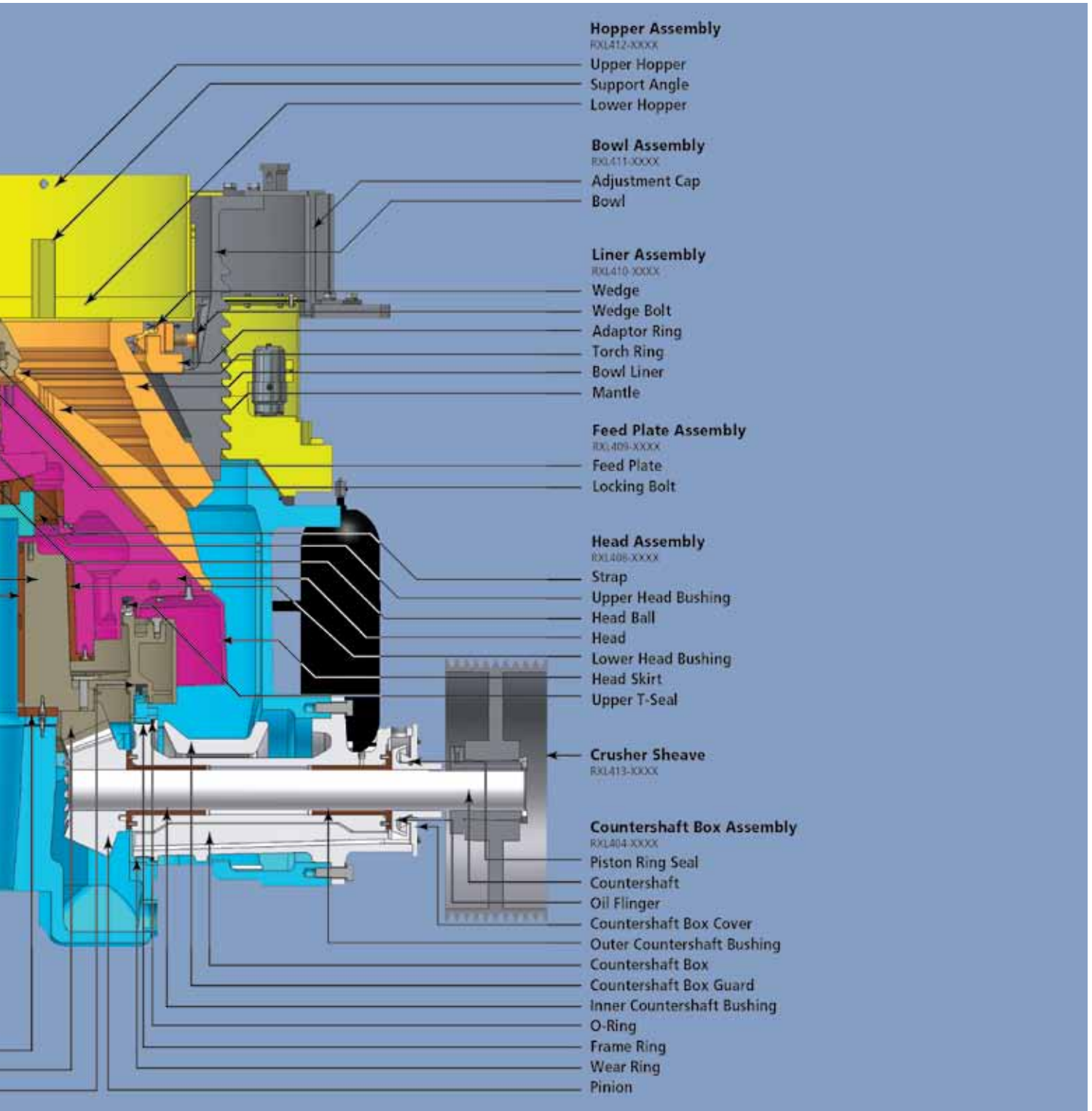

XL400 General Arrangement

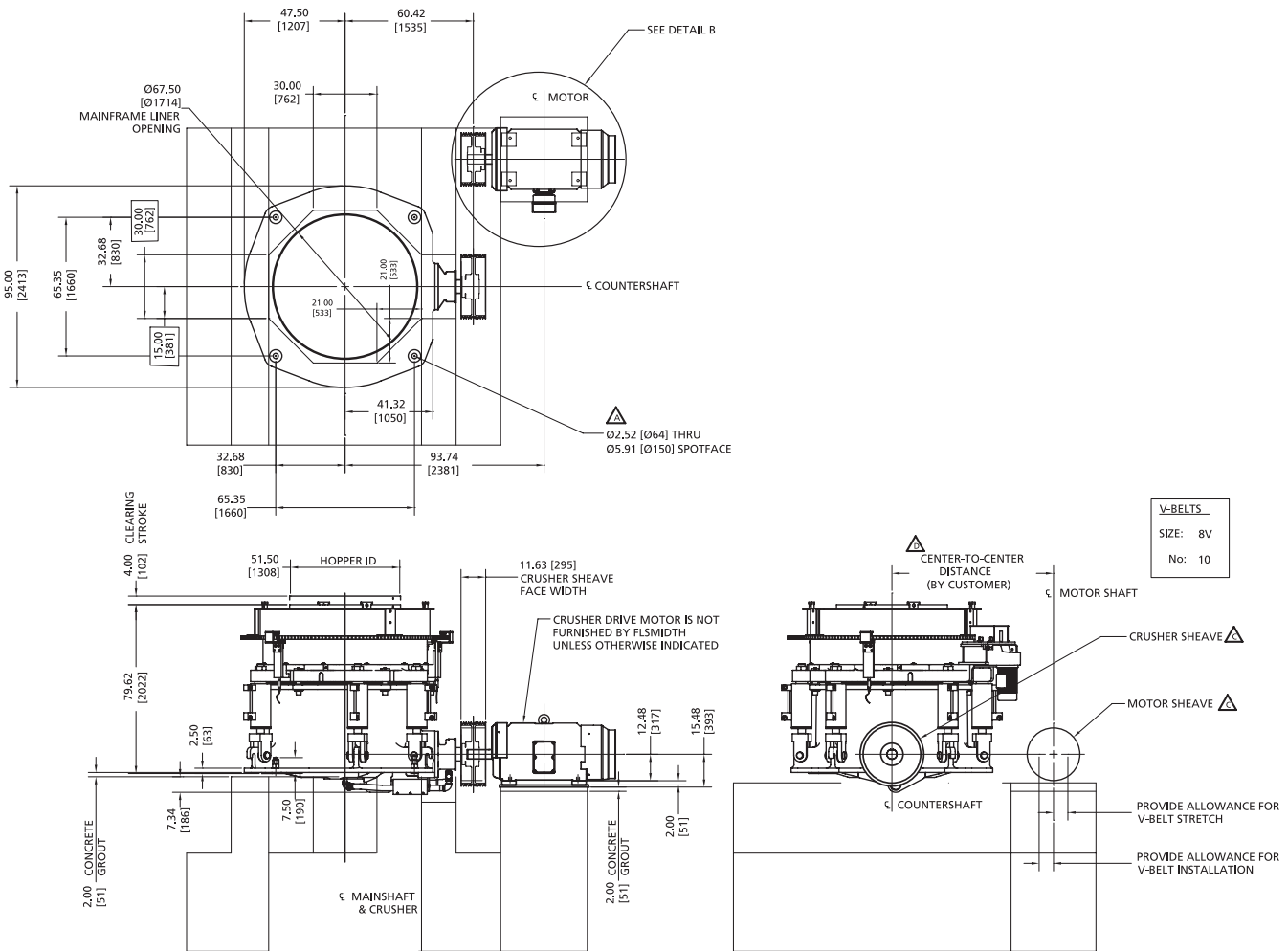

All dimensions are for reference only and are not to be used for construction.

Product Gradation Table

Percent Passing For a Given Closed Side Setting

Average Feed Material (12 to 14 wi)

Product Size	1/4" (6 mm)	3/8" (10 mm)	1/2" (13 mm)	5/8" (16 mm)	3/4" (19 mm)	7/8" (22 mm)	1" (25 mm)	1 1/4" (31 mm)	1 1/2" (38 mm)	2" (50 mm)
4" (100 mm)										100
3" (75 mm)									100	94-98
2" (50 mm)								96-99	89-95	65-71
1-1/2" (38 mm)						100	95-99	87-93	73-79	47-53
1" (25 mm)				95-99	92-97	82-88	71-77	46-52	37-43	25-31
3/4" (19 mm)		100	93-98	86-92	79-85	65-71	54-60	34-40	27-33	19-25
1/2" (13 mm)	100	89-95	75-81	63-69	52-58	40-46	33-39	19-25	15-21	11-17
3/8" (10 mm)	85-91	78-84	63-69	52-58	42-48	31-37	27-33	15-21	12-18	9-14
1/4" (6 mm)	75-81	52-58	40-46	33-39	26-32	19-25	16-21	9-15	6-12	4-11

Values listed will vary depending on feed distribution, cavity level, feed gradation, crushing chamber, moisture, and material density.

Raptor® XL400

Capacity Chart

	Setting mm	mt/hr Min	mt/hr Max	Setting Inches	stph Min	stph Max
Short Head Fine	10	165	215	3/8	180	235
Short Head Medium	13	210	275	1/2	230	300
Short Head Medium	16	260	340	5/8	285	375
Short Head Coarse	19	295	385	3/4	325	425
Standard Fine	22	310	405	7/8	340	445
Standard Fine	25	340	445	1	375	490
Standard Fine	32	390	510	1-1/4	430	560
Standard Medium	38	445	580	1-1/2	490	640
Standard Coarse	45	510	665	1-3/4	560	740
	Reduction Ratio	4 to 6	2 to 4	Reduction Ratio	4 to 6	2 to 4

As indicated above for 100 lbs. per cubic foot and impact work index of 13.
Short tons per hour based on open circuit crushing with material weighing 100 pounds per cubic foot. Values are estimated "instantaneous" product samples, actual values may vary $\pm 15\%$. Factors that will vary throughput are; feed gradation, cavity level, feed distribution, moisture content, and properties of the processed material.

Feed Openings

	Minimum Closed Side Setting "A"	Feed Size "B" at min. CSS "A"
Standard Coarse	.99" (25 mm)	12.70" (323 mm)
Standard Medium	.87" (22 mm)	9.79" (249 mm)
Standard Fine	.66" (17 mm)	6.93" (176 mm)
Short Head Coarse	.39" (10 mm)	5.59" (142 mm)
Short Head Medium	.38" (9 mm)	4.33" (110 mm)
Short Head Fine	.24" (6 mm)	3.27" (83 mm)

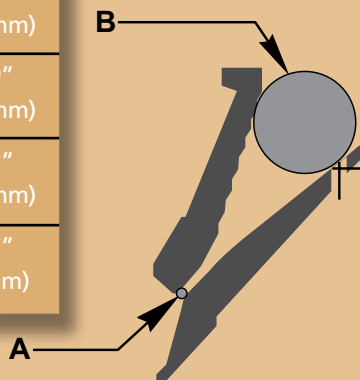

Lifting Weights

Main Lifting Items	(lbs.)	(kg)
Complete Crusher	51,790	23,490
Main Frame Assy (Includes Main Shaft and Frame Liner)	14,920	6,770
Bowl Assembly (Includes Bowl Liner and Hopper Assembly)	10,641	4,830
Adjustment Ring (Includes Clamping Ring)	6,770	3,070
Head Assembly (Feed Plate Assembly and Mantle)	7,930	3,600
Countershaft Box Assembly	1,230	560
Eccentric Assembly (Includes Counterweight)	3,950	1,800
Mantle	2,940	1,330
Bowl Liner	3,390	1,540
Power Unit		
Dry	740	340
Wet	1,110	500
Lube-Air		
Dry	1,590	720
Wet	2,410	1,100
Lube-Water		
Dry	1,490	660
Wet	2,430	1,100
Air Cooler	350	160

NOTE:

1. Allowable casting weights vary $\pm 5\%$.

Capabilities

www.flsmidth.com

Rev. 10/7/2011 a1-us

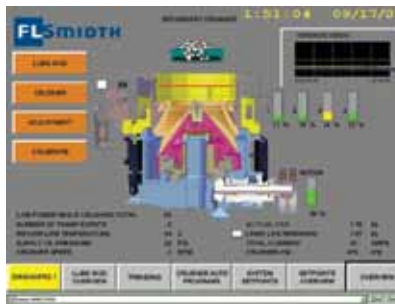

Automation

Raptor® automated controls improve cone crushing performance by ensuring the crusher operates at optimal efficiency:

- Available in five packages for all Raptor Cone Crusher models:
 - Basic Automation System
 - Automated Interlock System
 - Full Automation System
 - Custom Automation System
 - Remote Liner Calibration System
- Self-contained controllers provide full-time monitoring and automated controls

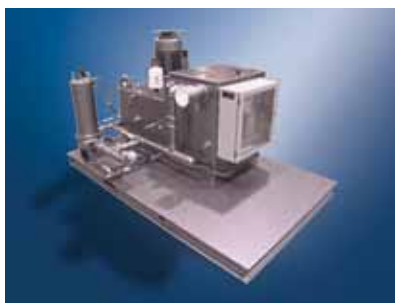

Package Lube & HPU

The **Package Lube System** is designed and sized to provide the necessary supply of clean and cooled lubrication oil and is available in an air-cooled or water-cooled package, depending on requirement. Both systems are skid-mounted, designed to operate at a maximum pressure of 125 psi (8.6 Bars) and include:

- Full flow oil filter with integral pressure relief
- Replaceable filter element and two pressure switches to indicate filter element conditions



- Reservoir with oil level sensor, temperature sensor and a thermowell mounted oil heater
- Submerged oil pump attached to a vertically positioned electric drive motor
- Main system relief valve
- Crusher relief valve

The **Hydraulic Power Unit** is designed and sized to provide the necessary oil flow and pressures to operate bowl clamping, bowl adjustment, crusher cavity clearing and the tramp release systems. The power unit can be controlled locally at the push button pendant or at the Automated Control System (ACS) touch screen.

The Hydraulic Power Unit includes:

- Cabinet with an integral oil tank and replaceable breather
- Vertically mounted electric motor
- Submerged hydraulic pump
- Solenoid valves
- Oil filter
- Remote-mounted pushbutton control panel

Mineral Processing Technology Center

FLSmidth Salt Lake City, Inc.
7158 S. FLSmidth Drive
Midvale, UT 84047-5559
Tel: +1 801-871-7000
Fax: +1 801-871-7001
E-mail: info.sl@flsmidth.com

Raptor Manufacturing Facility USA

FLSmidth Salt Lake City, Inc.
14425 Wagonseller Rd.
Pekin, IL 61554-8831
Tel: +1 309-353-9235
Fax: +1 309-353-5591
E-mail: RaptorSales@flsmidth.com