

BELT SCRAPERS

With ROSTA SE Tensioners

Belt scrapers utilising ROSTA SE tensioners are

- low cost
- low maintenance
- simple to install
- use superior technology and
- provide controlled tensioning

THE SMART CHOICE

Belt scrapers using ROSTA SE tensioners can cost a quarter of the price of some scrapers, and can easily be fabricated in your own workshop. The ROSTA units provide positive tension on the belt over the life of the scraper blade, require little or no adjustment once installed, and provide highly effective cleaning.

What's more, the belt scrapers don't need expensive, high-tech scraper blades that constantly require replacement. The self-adjusting ROSTA units allow most applications to work well with just a strip of black rubber.

ROSTA SE tensioners are regularly utilised in belt scraper systems for the mining, quarrying, agricultural, timber and food processing industries and they are also available in AISA 304 food industry grade stainless steel.



BELT SCRAPERS

With ROSTA SE Tensioners

GENERAL ARRANGEMENT

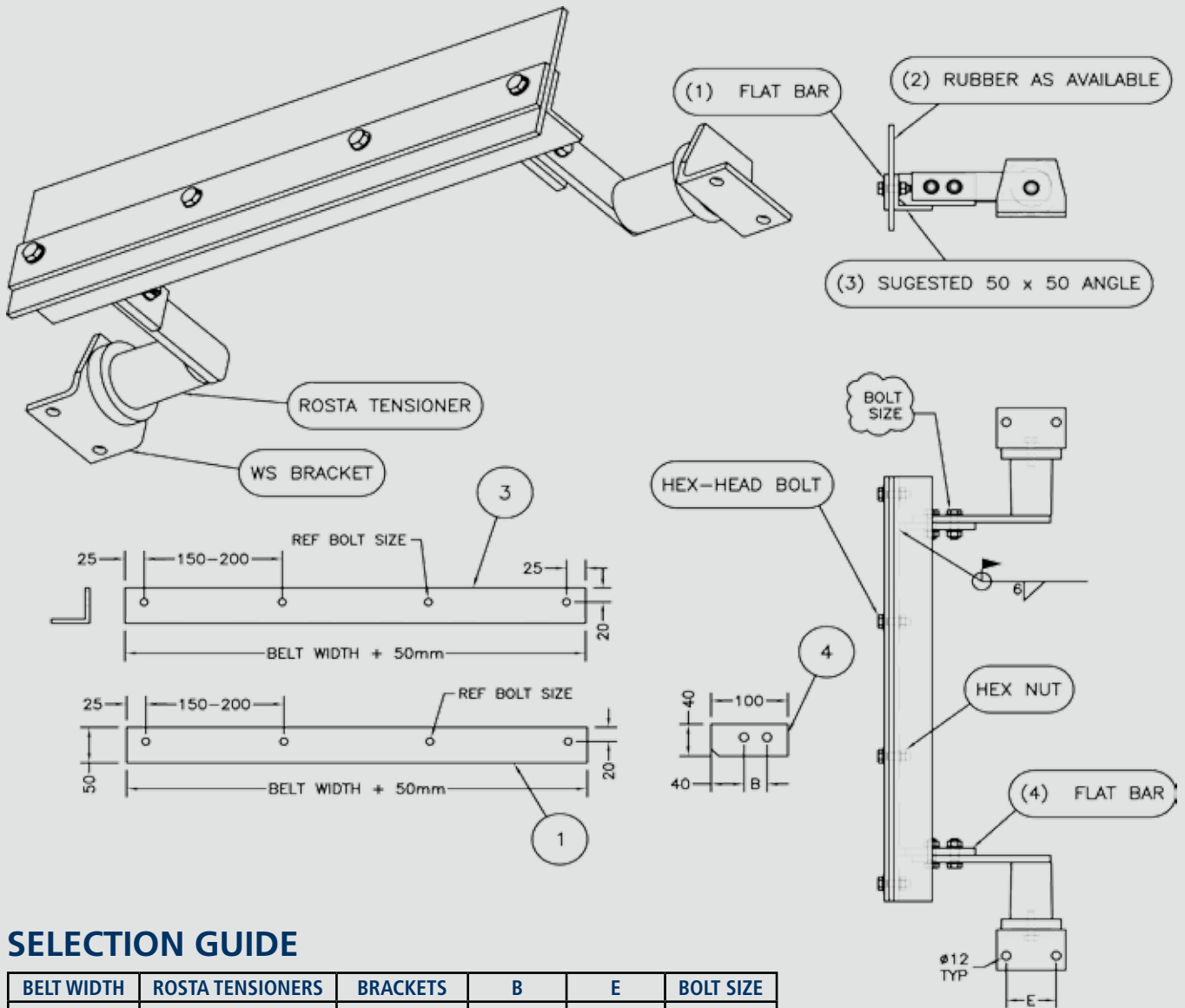

SELECTION GUIDE

BELT WIDTH	ROSTA TENSIONERS	BRACKETS	B	E	BOLT SIZE
450mm	2x SE 18	WS 18-27	20	50	M10
600mm	2x SE 27	WS 27-38	30	65	M12
750mm	2x SE 27	WS 27-38	30	65	M12
900mm	2x SE 38	WS 38-45	35	80	M20
1050mm	2x SE 45	WS 45-50	45	100	M20
1200mm	2x SE 45	WS 45-50	45	100	M20

Dimensioners in mm

Stainless steel and heat resistant tensioners are also available.



Crushing & Mining Equipment

PERTH 08 9437 1477 | SYDNEY 02 9838 1411 | BRISBANE 07 3382 0611 | MELBOURNE 0417 934 879
 sales@crushingandmining.com.au | www.crushingandmining.com.au